

WOODFLEX CLIP SYSTEM INSTALLATION INSTRUCTIONS

PRE-INSTALLATION SITE INSPECTION

Before you begin installing your WoodFlex Clip System floor, read these instructions from start to finish. If you have any questions, contact Allied Products, LLC at 1-800-864-1272.

Tools and Materials List:

Broom	Hammer	Saw	Chalk Line
Head Joint Adhesive	Table Saw	Crowbar	Crow Bar
Jamb Saw	Cut-Off Saw	Polyfelt Underlayment	Wall Spacers

1. Visual Inspection

All new homes and renovation projects must be weather tight. All doors and windows must be installed prior to installation.

A. Exterior Checks

- Check the eaves overhang. Is all rain water carried away from the foundation?
- Inspect the rain gutters and downspouts. Is all rain water being drained away from the foundation?
- Check exterior grading. Will rainfall or landscape irrigation flood the slab or flow into the crawl space under the house (raised foundation)? Exterior soil elevation and slope are important factors in the house being able to shed water. Note: Is the exterior landscape/hardscape lower than the edge of the foundation? Does the lot slope away from the structure for proper drainage.
- Does the house have raised flowerbeds or planter boxes that adjoin the foundation? If yes, a moisture barrier must be installed by a landscaper.
- Is there an outdoor pool or natural body of water higher than the foundation that can overflow and flood the floor?
- If the home has a raised foundation, are exterior vents open and unrestricted?
- Size of available vents should equal 1.5% of the square footage within the crawl space.

B. Interior Checks

- Does the interior have a musty smell?
- Check all sinks, toilets, dishwashers, refrigerator icemakers, and laundry rooms for leaks.
- Do outside doors, sliding glass doors, and windows appear to be properly sealed and are adjacent areas dry?
- Is HVAC operational?

2. Subfloor Moisture Testing – Concrete

WoodFlex can be installed in rooms with normal humidity levels on subfloors that are firm, level, and dry. To determine if a concrete subfloor is dry, several methods can be used.

Method A: Place a sheet of plastic film or rubber mat on the surface of the subfloor and seal the edges with duct tape. If after 24 hours condensation or darkening does not occur, the subfloor is dry. If condensation or darkening does occur, refer to Method B.

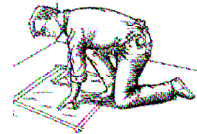

Method B: Should Method A indicate moisture, a 72-hour calcium chloride test needs to be conducted on the concrete subfloor (ASTM F-1869). For emission levels of up to 6 lbs of pressure use Polyfelt with fully taped seams. For levels between 6 and 8 lbs use 6 mil. plastic underneath as a secondary moisture barrier. See page 4, *Secondary Vapor Barrier for additional information*. For readings in excess of 8 lbs., corrective measures must be taken in order to successfully install WoodFlex. **Caution:** Calcium Chloride readings can fluctuate seasonally, and the maximum rating of the two-part system is 10 lbs.

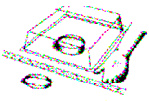

Subfloor Moisture Testing – Wood

Test wood subfloor with probe-type moisture meter. Check moisture content at several places in the room and calculate the average. In most areas, a subfloor is considered dry and ready for flooring if the moisture content is 12% or lower. If moisture content is higher, do not proceed until source of moisture has been determined, eliminated, and the subfloor moisture content is within specifications. The moisture content of the WoodFlex floor and subfloor should not vary by more than 4%. Subfloor materials should be purchased from a supplier that stores the material indoors. Materials that have been stored improperly could contain high levels of moisture.

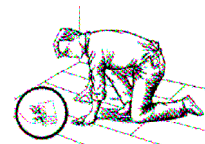

PREPARING FOR INSTALLATION

1. Subfloor Tolerance

Subfloors should be a firm surface such as concrete or plywood. Existing floor coverings, such as sheet vinyl or smooth tiles do not need to be removed as long as they are firmly attached to the subfloor. Surface variation should not exceed 3/16" within a ten-foot radius or 1/8" within a six-foot radius (NWFA specification). To determine flatness of the subfloor, use the edge of a straightedge or a level. Correct minor low spots by filling with roofing felt or Kraft paper (on top of Polyfelt). Extensive low spots may require a leveling compound. Scrape, sand, or grind any high areas.

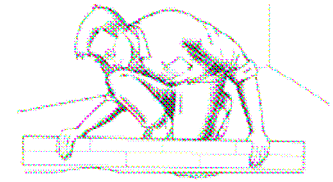

2. Crawl Space Ventilation

Adequate cross-ventilation must exist to allow proper air movement. Inadequate ventilation may result in increased humidity levels in crawl space. Size of crawl space vents should equal 1.5% of the square footage within crawl space. Soil must be dry and crawl space must be free from water. Lay 6 mil. plastic on the soil under the structure with seams overlapping 12". Seal the seam along its entire length with duct tape. The distance from soil level to the underside of the subfloor should be a minimum of 24" (NWFA specification).

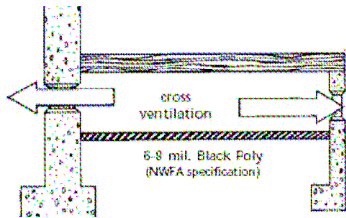

3. Clean Subfloor

Scrape subfloor clean and sweep up all debris from construction site. Any debris left on the floor could compromise the vapor barrier.

4. Determine Direction of Installation

Decide which direction your flooring will be installed. The rule of thumb is to run the length of the flooring with the longest direction of the room. Other considerations are to install planks parallel to the incoming light source or parallel to the direction of traffic flow. **Note:** If floor is being installed over wood subfloor with joists, the floor should run perpendicular to the joists. If the floor must be run in the same direction of the joists, it may be necessary to reinforce the subfloor with 3/8" or 1/2" plywood screwed to the joists to firm up the subfloor. When the subfloor is dimensional lumber (1x6) installed on a 45° angle over joists, the hardwood flooring cannot be installed on the same 45° angle as the lumber subfloor. If the flooring must be installed in the same direction as the lumber subfloor, a secondary subfloor must be installed by attaching 1/2" plywood directly to the joists with screws.

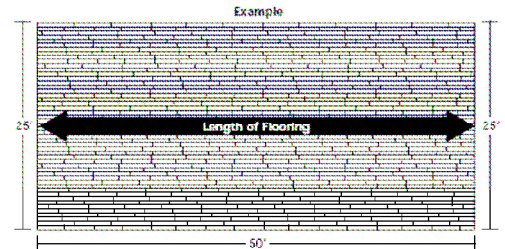

5. Clip Sizes/Selection

Climatic conditions vary from one geographic area to another. The relative humidity will affect the movement of the boards. Allied Products flooring boards are dried to a level equivalent to 50% relative humidity. All hardwood flooring will experience seasonal humidity swings. When selecting a clip size, review the map below and determine which climate zone applies to your installation site and select the appropriate clip.

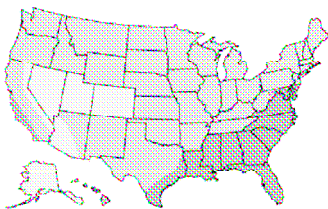

Climate Zone	Anticipated Site Conditions	Relative Humidity	Floor Moisture Content	Clip Size/Name
1	Extremely Dry	10% - 30%	3.0 - 6.0	128.8 / Small
2	Comfortable	30% - 50%	6.0 - 9.0	129.1 / Standard
3	Humid	45% - 65%	7.5 - 12.0	129.4 / Large
4	Extra Humid	60% - 90%	10.5 - 16.0	129.8 / Extra Large

This chart is intended for general use. Factors such as heat and additional moisture from structural or plumbing leaks, lack of climate control before and after installation, and improper maintenance will have additional impact on board size and moisture content

The relative humidity range indicated on the chart shows the high and low relative humidity ranges of each zone. At the highest humidity percentage, the boards will "expand" in the width. At the lowest humidity percentage, boards will "contract" and become narrower. This represents the normal movement associated with seasonal changes in relative humidity.

Climate Zone 1: This geographic area represents a lower humidity cycle of 10%-30%. It is necessary in this drier/low-humidity zone to contract the boards in width and establish a lower moisture content in the boards through acclimation. The boards should be contracted/acclimated to represent the upper (more humid) end of the humidity cycle for this zone. If the relative humidity is at the drier (lower) end of the humidity cycle, a humidifier can be used to prevent over-drying (over-contracting) of the boards. To acclimate, remove material from boxes, cross-stack to promote air movement to all sides of the flooring and allow the boards to “contract” to the appropriate size and moisture content. The boards will now have room to contract further (during low-end of humidity swing) and expand back in size (during high-end of humidity swing). After acclimation occurs, the small (128.8 mm) clip is used.

Climate Zones 2,3, & 4: When using the Clip System in these zones, acclimation is not required. The appropriate size clip will allow the floor to adjust naturally after installation.

Expansion & Contraction Planning

1. Planning for Expansion

It is vital in the planning of the job layout that you understand the unique nature of the flooring. This is not a veneer product (plywood); it is solid wood throughout. Always allow for proper expansion space around the perimeter of the floor. The rule is 1/4" expansion space for every 10' of width **ON BOTH SIDES!** The rule for expansion on the length is 1/8" for every 20' of length on both ends with a 1/2" minimum.

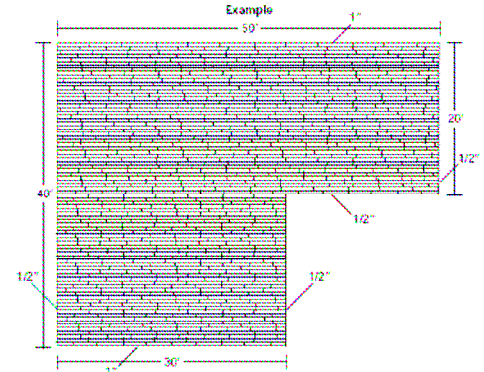

2. Expansion Space – Doing the Math

To calculate the correct expansion space for width of floor use the following table:

Expansion formula = 1/4" per 10 foot of span each side, 1/2" minimum per side.	
20 ft. span = 1/2" expansion per side	
30 ft. span = 3/4" expansion per side	
40 ft. span = 1" expansion per side	
50 ft. span = 1-1/4" expansion per side	

3. Allowing for Expansion

Remove any existing wall base, molding, or doorway thresholds. These items can be replaced after installation. Door casings should be undercut and notched out to avoid difficult scribe cuts and provide for proper expansion space. This is easily done by placing a flooring board on top of the Polyfelt against the frame and sawing the doorjamb. The flooring can then slide under the doorframe.

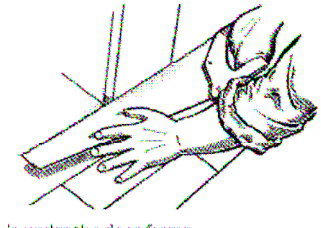

4. Undercutting Wall Base

When spans larger than 20' exist, it may be necessary to find additional expansion space for the floor. This can be achieved by undercutting the wall base. Remember to adjust for the thickness of the Polyfelt when setting the height of the jamb saw. Add an additional 1/8" to the height of jamb saw to allow room for the tuck needed at exterior walls.

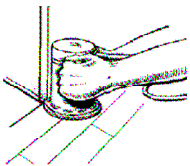

5. Expansion Space for Larger Spans

If wall base cannot be removed, undercut wall base and drywall to allow maximum expansion space at the walls. If wall base is off, undercut the drywall. Make sure the cut is high enough to make room for Polyfelt and for the tuck you need at perimeter walls.

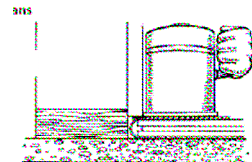

CAUTION: DO NOT CUT SILL PLATE! This will cause structural damage to the dwelling. Review the chart on page 3 to determine if your installation requires these measures.

PRE-INSTALLATION MATERIAL INSPECTION

1. Inspect Materials

Examine all materials for any defects *before* installation and confirm the color, species, style and thickness. Should any defects be present, **STOP THE JOB** and contact Allied Products right away. Do not install any plank that is obviously defective. Allied Products, LLC will arrange to view the job or view samples of the material as soon as possible. Allied Products strives to offer a product that is second to none in quality. However, the time to correct a possible defect is before the material is installed.

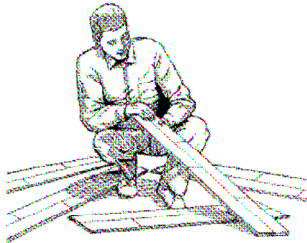

2. Polyfilm Backer

Some flooring materials have a plastic film adhered to the back of the board. This is designed to balance the top surface with the underside of the plank, which makes for a more dimensionally stable floor.

Do not remove Polyfilm backer!!

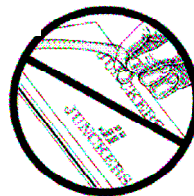

PREPARING FOR INSTALLATION – UNDERLAYMENT

1. Secondary Vapor Barrier

Should the preliminary moisture tests exceed specifications, an additional layer of 6 mil. plastic is required. Run plastic 4 inches up wall and tape in place with 3M blue painter's tape. Overlap plastic 8 inches and tape seam with duct tape. Lay plastic in opposite direction of Polyfelt to avoid joints lining up. Run line of duct tape on seam and where plastic meets subfloor. Note: Secondary barrier **MUST** be used in basement or over radiant heat systems incased in concrete.

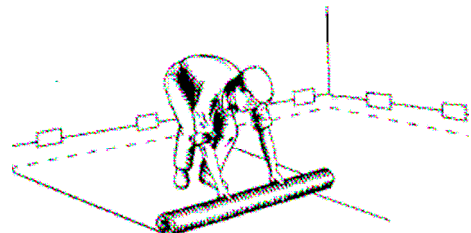

2. Installing Polyfelt

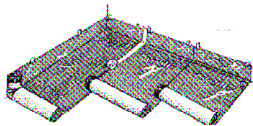

Loose lay Polyfelt with the **plastic side up**. Overlap the built-in flange on the side of the roll and **seal the seam along its entire length with duct tape**. Extend the Polyfelt 4 inches up the wall and tape in place with 3M blue painter's tape to hold it up and out of the way. This extra vertical material will create the lap necessary to minimize moisture invasion through the perimeter walls and the walls next to kitchens and bathrooms. Should the floor have a plastic membrane under the Polyfelt, it should be lapped and trimmed as well, see *Secondary Vapor Barrier above*.

CAUTION: Lapping underlayment systems at walls will not prevent moisture from penetrating the building and or damaging hardwood floors. Lapping at walls will minimize opportunity for damage from minimal condensation in walls and represents a prudent precaution. All buildings must have proper drainage, be weather tight and dry. Note: At end seams, butt the ends together and place a single layer of duct tape directly over the seam. Apply an additional piece of duct tape on each side of the seam piece overlapping 1/2" with the tape on both sides. **Do not overlap ends of Polyfelt.**

Note: Make sure you trim your expansion cavity high enough to accommodate all the material that will be involved in the tuck.

INSTALLING CLIP SYSTEM

1. Starting Line

Choose a long, straight wall as your starting wall. To start your first row of boards tack and stretch string 1/2" away from wall and 1/2" above surface of the floor height. The string acts as a guide to help keep the boards in a straight line.

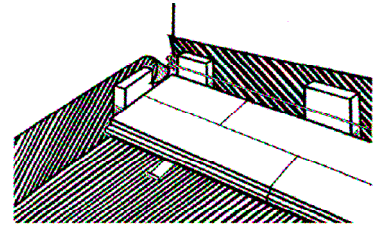

2. Expansion Space

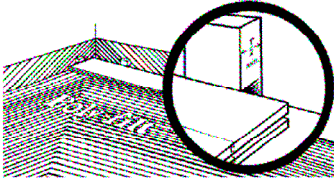

A minimum space of 1/2" must be left along all perimeter walls and other vertical obstructions. Extra large rooms or wide runs of flooring will require larger expansion gaps. For runs wider than 20' see page 3.

3. Lap Polyfelt & Secondary Barrier up Walls

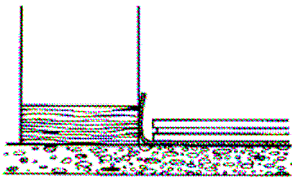

4. Tuck & Wrap with Undercut

It is important to protect the edge of the floor from moisture condensation at exterior walls and at walls that join to kitchens and bathrooms. Take a piece of flooring and gently push the underlayment into the cavity. Lay your row of flooring to where you want the edge to be according to your expansion needs.

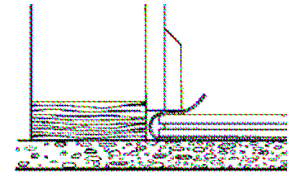

5. Cut Tuck Remnant

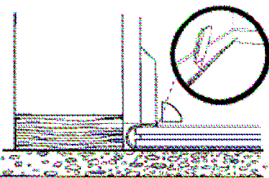

Cut off excess material from tuck-and-wrap process. Remember to check your clearance to insure floor can easily move in and out of expansion cavity. Make sure clearance is uniform around entire perimeter. A high area of the slab could result in a section of the floor not being able to move freely.

6. Irregular & Out-of-Square Walls

If your starting or ending wall is irregular or out-of-square, scribe and cut that first row to match variations. A simple scribe can be made by drilling a pencil-sized hole the appropriate expansion space from the wall. Mark the irregular surface onto plank to be cut.

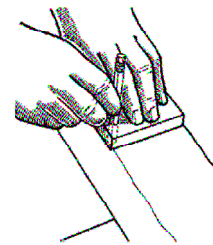
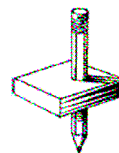

7. Starting Row

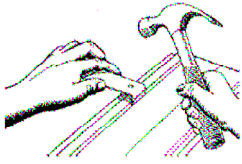

Begin in the left-hand corner with a full, uncut plank. Lay the plank upside down and hammer the end of the clip with the hole(s) into the clip groove (slot) on the underside of the plank. The long end of the clip without hole(s) must project in the direction of the tongue.

Small 128.8 mm
RH 10% - 30% (0.3 mm gap)

Standard 129.1 mm
RH 30% - 50% (0.1 mm gap)

Large 129.4 mm
RH 45% - 65% (0.4 mm gap)

Extra Large 129.8 mm
RH 60% - 100% (0.8 mm gap)

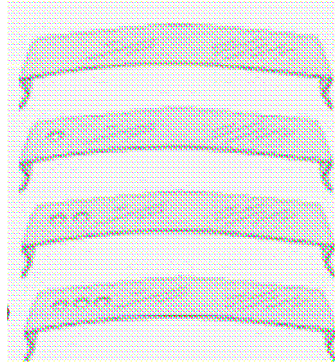

8. Marking Starting Row

It is vital to establish clip spacing and clip offset to maintain integrity of the clip system. Wandering clip spacing or offset will cause end-joint separation and irregular gapping in the floor. Starting with a full-length board, lay out the entire starting row upside down with the end-tongue and groove together. Using an 18" tapping block (as shown) place a 4" mark from end, and make an additional mark every 18" on center for two-strip products (7/8" & 9/16" thick), and every 12" on center for wide board products (3/4" thick), with the last mark on the row being 2" from the wall.

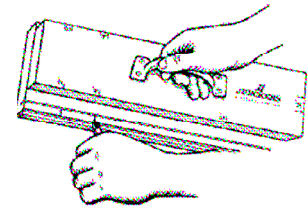
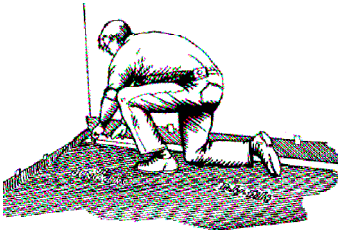

9. Plank Type

For ease of handling and quick installation, flooring strips have been pre-assembled into flooring planks. The typical size is 5" wide x 6' long.

Each full board covers an area of about 2.5 square feet.

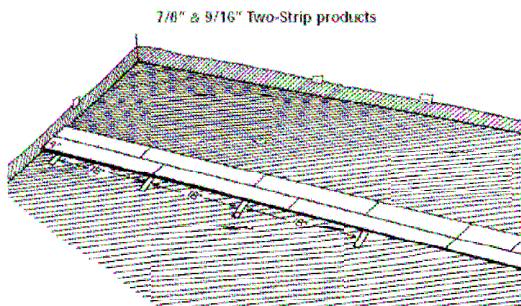

Mark every 18" on center for two-strip products (7/8" & 9/16").

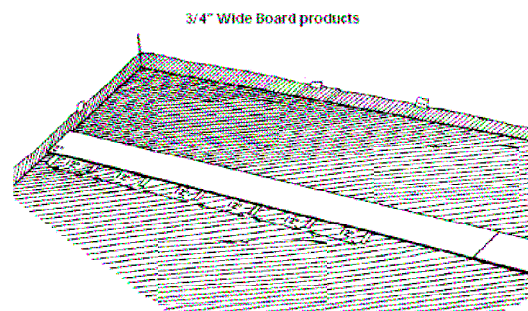

Mark every 12" on center for wide board products (3/4").

10. NO RUBBER MALLETS! USE TAPPING BLOCK ONLY.

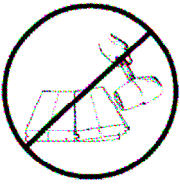

11. Clip Spacing

The distance between the clips should be about 18" on center (averaging four clips per six-foot plank). The first and last clip at the end of each row must be 2" to 4" from the wall. *Important: On all Wide Board products (see page 6, 3/4" Wide Board products), clip spacing should be changed to 12" on center (six clips per six-foot plank).*

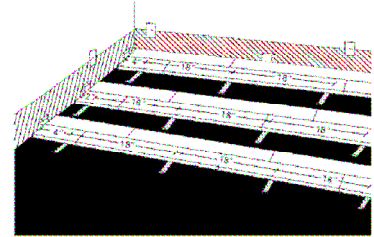

12. Clip Planks Together

Glue and place the end-joints together first; then use a hammer and tapping block against tongue to tap boards firmly together along the length. When the planks are tight, press down on the plank to engage the clip. To effectively seat the end-joint, tap board into place starting at its open end and tapping back along its length into the floor. **End-joints must be tight prior to engaging clips. Note: Do not strike the edge of the board with the hammer or drive boards together too hard. This will damage the edges of the board.**

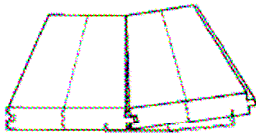

- A. Insert end-joint over clips.
- B. Push end-joints together.
- C. Tap planks together (with a tapping block) gently from front end back toward the end-joint to tighten the end-joint.

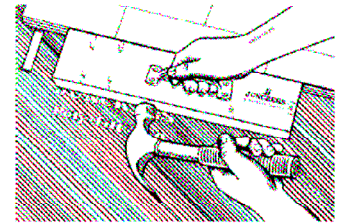

Note: Be sure end-joints are tight prior to seating clips.

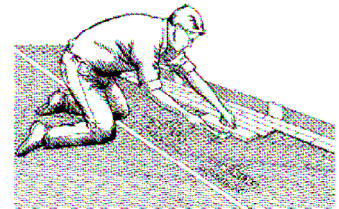

13. Glue End-Joints

Once the clips are in, turn the plank right side up and install the first board with the groove side toward the starting wall. The tongue side will be away from the wall with the long arm of the clip exposed. Apply header joint adhesive to the inside bottom of the end-joint groove (as shown) and repeat with succeeding boards to complete the first row. **Note:** Lead with groove end, left to right.

CAUTION: DO NOT apply adhesive to the sides of the plank!

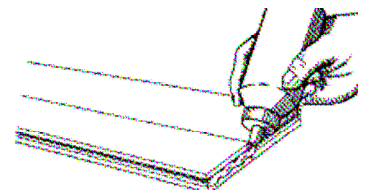
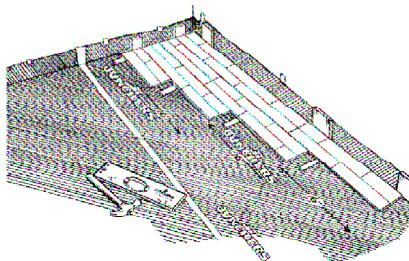

14. Starting Next Row & End-Joint Spacing

To start the next row of boards, begin with the cut piece left over from the first row (if cut piece is under 16", cut a new piece at least 16" from a full plank to stagger the end-joint). This end gap spacing is critical to the structural integrity of the floor. Spacing the end-joints 16" or more creates proper interlocking strength in the floor. To prevent clips from touching each other, alternate them (in line) by approximately 2" back and forth as you proceed across the floor. To create a random end-joint pattern, stagger end-joints of boards by at least 16".

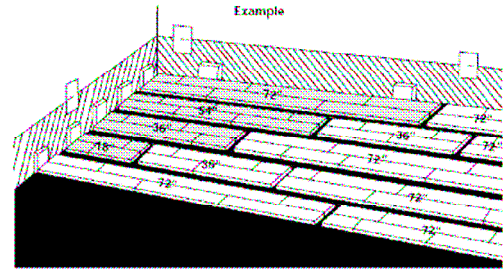

15. Clip Spacing at Corners

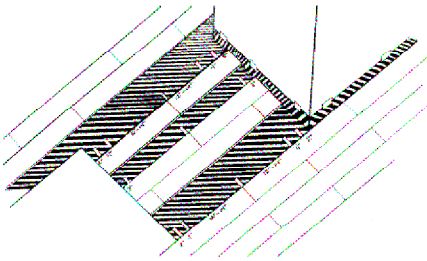

Clips need to be doubled up at places where the floor turns a corner or goes through a doorway. It is also important to narrow the clip spacing to 12"-14" and place clips within 2"-4" at ends when you go through a narrow aisle-way. Using this method in narrow aisle-ways between a kitchen counter and kitchen island will help prevent gaps from occurring.

16. Changing Installation Direction

It is not possible to lay WoodFlex backwards, i.e. by leading with the groove and short end of the clip. When it is necessary to reverse the direction of the installation, the doublewide clip is required to ensure a strong joint. The slip-tongue is glued into place. **Note:** For better fit and joint strength, pre-sand the slip-tongue with 60-grit sandpaper to round the edges and smooth the slip-tongue. Use a brush or piece of cardboard to paint the inside of the groove with glue. This provides an even distribution of glue and provides a tighter, stronger glue joint. Place weight on the surface to insure that the joint is flat while drying.

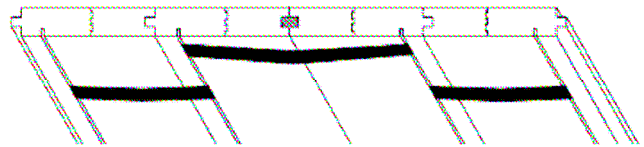

17. Transition through Interior Doors

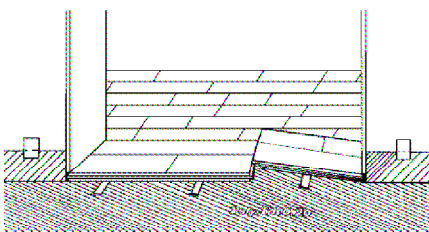

Using an end-joint seam in the center of the door allows the board ends to be installed under the doorjamb and clear the clips. Install the board with the tongue end first. Remove the bottom of the end-groove of the next board. Secure modified end-joint with header joint adhesive and tape joint together with painter's tape, and weight down joint until dry.

18. Fitting Last Row

Cut the last row of planks as needed to fit in the remaining space. Remember to allow for the expansion gap at the wall. If needed, the width of the last row of planks can be scribed with a pencil, see page 5 *Irregular & Out-of-Square Walls*.

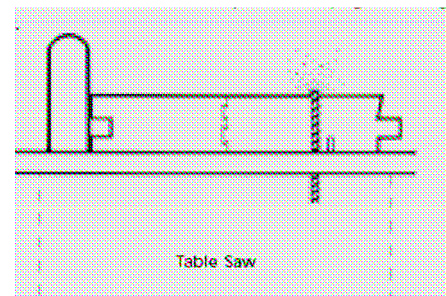

19. Installation of Last Row

The final ripped down board must be glued to the preceding row by applying header joint adhesive along its length (side). The last row is the only exception to applying header joint adhesive to the length (side). Do not apply header joint adhesive to the sides (length) of the boards in the field of the floor. Use a brush or piece of cardboard to paint the groove with glue create an even film.

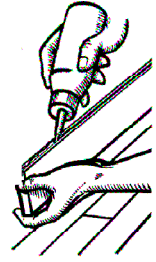

20. Snugging up Last Board



When the last board is cut to its proper width, use a pull tool or crow bar to snug up the last board. Use a shim against the wall to avoid damage to the wall. Make sure all joints are tight and proper expansion space is left between all walls and the completed floor.

21. Radiator Pipes

If the room has pipes or radiators, drill a hole large enough to fit around them with space for expansion. Then saw diagonally away from hole(s). Fit board around pipe or feet of radiator and replace cutaway piece.

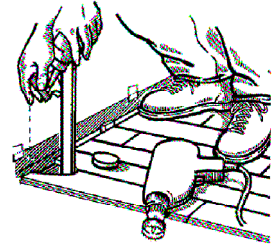

22. Securing Wall Base & Base Shoe Moldings

It is vitally important to secure moldings in a fashion that does not restrict the ability of the floor to move. Wall base and base shoe moldings should never be fastened to the surface of the floor. The correct method of securing these types of moldings is to fasten them to the wall with nails. For lip-over molding installation, see below.

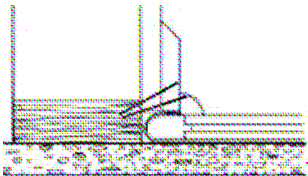

MOLDINGS, THE FINISHING TOUCH

Matching Wall Base

This stylish molding adds a luxurious look for the transition from floor to walls. Available in size 3/4" x 3-1/2" x 96".

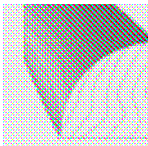

Base Shoe Molding

This versatile molding is used primarily in conjunction with matching wall base or existing wall base to hide the contraction and expansion space.

Baby Threshold (Lip-Over)

Provides a transition from wood flooring to carpet, at sliding glass doors, fireplace hearths, and exterior door thresholds. For installation method, see "special notes" page 10.

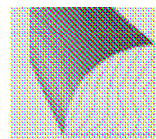

T-Molding (Lip-Over)

To be used when any two level surfaces meet, such as wood flooring to wood flooring or wood flooring to tile. Often used at a door or to create a break in the floor when changing direction.
Note: For floors with spans in excess of 40' look for opportunities to use this molding to create an expansion break. For installation method, see "Special Notes" below.

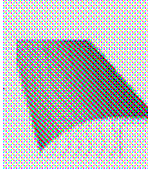

Lip-Over Reducer

This is used for transition from wood flooring to thinner floor coverings. It can also be used as a transition to low-pile carpet or vinyl. *Note: For a clean match up to low-pile carpet, trim front of reducer to match carpet profile.* For installation method, see "Special Notes" below.

Lip-Over Stair Nosing

Provides transition from horizontal to vertical surfaces. *Note: Flush stair nose is available for stair tread construction and for use in nail-down installation (see Nail-Down Installation Instructions).*

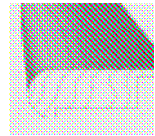

SPECIAL NOTES

- Do not attach lip-over moldings directly through the lip-over part of the molding. These types of moldings are to be secured by the use of epoxy, liquid nail or fastened with nails directly to the subfloor. It is critical that the movement in a floating system is not impeded or restricted in any way.
- Some molding profiles noted in this section are available in a flexible format. These can be purchased through Resinart at 949-642-3665 and are offered unfinished only. *Note: This is a custom item not carried by Allied Products, LLC.*
- Sub-floor must be very flat at all molding transitions to ensure a proper fit. If flooring is allowed to flex beneath the lip-over molding, the molding could crack or break.
- Do not install built-in cabinets on top of floor. Install cabinets prior to installation of the floor.

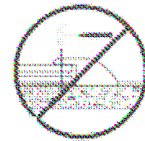

False Toe Kick

For use against cabinets where spans exceed capacity of a base shoe molding, an unfinished piece of 3/4" material can be used to create a false toe kick. Once cut to size, it should be matched to the color of the cabinets. In new construction, the cabinet companies generally have the capability to manufacture matching material. When attached to the front of the toe kick, the false toe kick will provide the additional space required by a large span.
Note: This is a custom item not carried by Allied Products, LLC.

REPAIR TECHNIQUES

Tools & Materials List

3M Blue Painter's Tape	Pry-bar
3M Maroon Pad	Rubber Mallet
Adhesive Remover (Goof Off)	Safety Glasses
Broom/Shop Vacuum	Sandpaper (assortment)
Chisels (assortment)	Skil Saw
Epoxy (5 minute, 2-part)	Table Saw
Finish Hammer	Utility Knife

- Before you begin: Replacement planks may be a different width than the planks already in the floor. If needed, allow replacement material to acclimate to the climatic conditions in the home. *Note: To check size, lay replacement plank upside down on top of board to be replaced. When width is the same as the board to be repaired the repair can proceed. Set the replacement material out of the box in the same room as the repair, the replacement material will assume the same width and moisture content as the rest of the floor in time.*

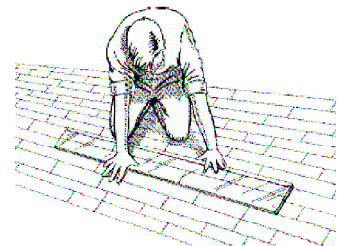

2. To remove the board, set saw cutting depth to match the thickness of the floor. Run two cuts along the length of the plank about 1/2" from the side.

Caution: Do not cut into adjoining boards.

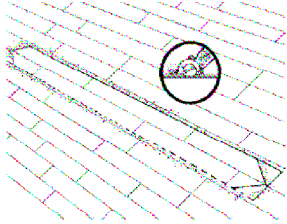
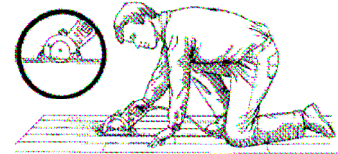

3. Make V-shaped cuts at the ends of plank. Angle saw and slowly lower saw into surface of plank. **Caution: Do not cut into adjoining plank.**

4. Break the end glue joint by hitting it a couple times with a white rubber mallet or rubber hammer after the saw cuts are made. **Note:** A block of wood can be placed on the surface with a piece of Polyfelt under it to prevent scratches when using a conventional hammer.

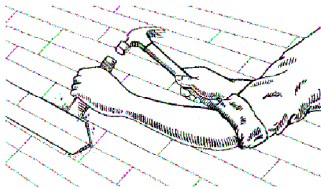
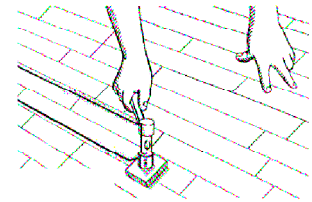

5. Remove the center of the plank using a pry-bar and a selection of wood chisels. Use the larger chisels to remove the large pieces, and the small paring chisels to remove the material at the joint where the planks come together. Use chisel to tap out sides and corners.

6. Using a pry-bar, lift the edge of the plank and remove any exposed clips. This is easily achieved if you twist the clip downwards and rotate.

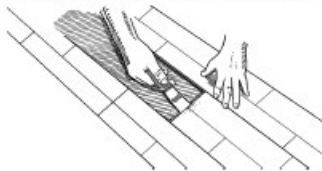
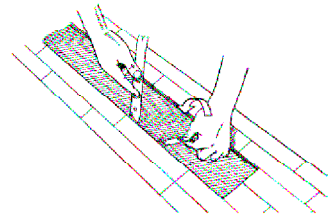

7. Remove any excess glue debris from the top of end-joint tongue and groove. Use a small scraper, putty knife, or chisel to carefully do this. **Note:** Use care not to damage the end-joint tongue and groove. If they are damaged the repair board will not fit flush. If the end-joint tongue and groove is damaged, it will be necessary to use a router and a spline-joint bit to create a clean new groove for the insertion of a slip-tongue.

8. During the course of the board removal, the Polyfelt may have been damaged. Repair the Polyfelt with duct tape. If large holes exist, use a piece of 6-mil. plastic to create a patch. If a secondary vapor barrier is under the Polyfelt, make sure the barrier remains undamaged. It is crucial that the floor not be exposed to subfloor moisture.

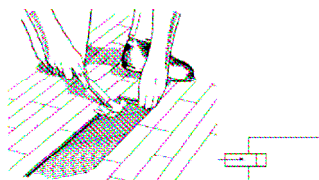
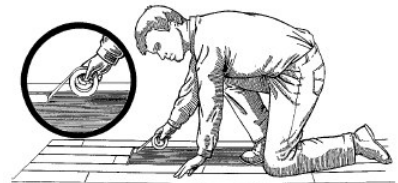

9. Cut slip-tongue to size and glue into groove end-joint in the floor.

10. To remove bottom of groove on the side (long length) of the board, set blade at a 30° angle. Set fence so about 1/16" of the groove remains after making the cut. This allows the board to click into place and helps hold the board in place while the glue dries. **Caution: Do not set the saw blade too deep or the fence too far away. The precision of this will impact the quality of the repair.**

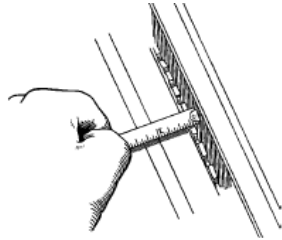
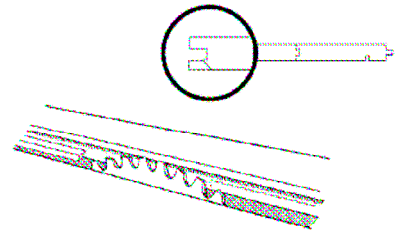

11. To set up table saw to modify end-groove and end-tongue, set fence 1/4" away from saw blade.

12. Using miter guide on the table saw, set the rip fence and remove the tongue from the end of the replacement board. A chop saw should not be used as it can damage or shorten the end of the board. **Note: Do not remove the side tongue of replacement plank.**

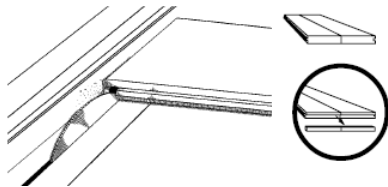
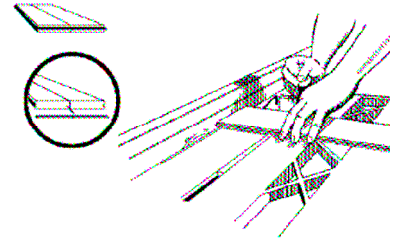

13. Remove bottom of butt end created by removal of the end-tongue. Make three passes using the miter guide with a person at the end of the board to help steady the board. First pass directly against fence. Second pass a little further from the fence, and the last pass right near the edge of the end.

14. Remove bottom of end-groove.

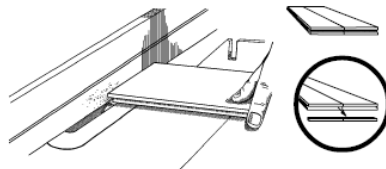

15. To remove debris left during the three passes, it is important to run the end of the board back and forth into the blade using the rip fence as a stop. This will clean up the rabbit joint just created. Test with a piece of flooring with tongue on end to ensure edge will fit flush.

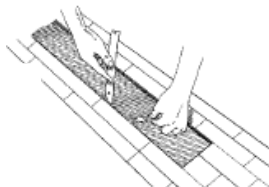

16. Lift edge of opening that has an exposed tongue using a pry-bar. Feel under the edge for the location of existing clips. Use blue painter's tape to mark the location of the clips coming from the adjoining board. Once the clips are located, use pry-bar to lift the edge of the plank and slide the clip until finding the clip groove. Set the clip by placing a block on the top of the floor, over the clip, and strike the block.

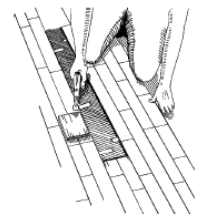

17. Lift edge of opening that has the groove using a pry-bar. Feel under the edge for the location of existing clips. Use blue painter's tape to mark the location of the clips coming from the adjoining board. Once the clips are located, use pry-bar to lift the edge of the plank and slide the clip until finding the clip groove. Setting the clips on this side will only leave an area of about 3/4" exposed. Set the clip by placing a block on the top of the floor and strike the block.

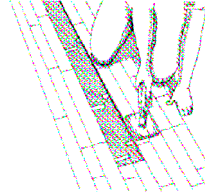
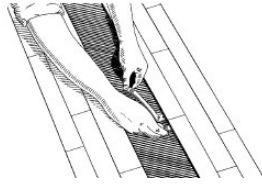

18. Check the boards adjacent to the repair cavity for deflection. If a low spot exists in the center of the repair area, it may be necessary to shim up the center or ends. This ensures that the repair board seats properly and that no excessive deflection exists, which may promote failure of the glue joints in the repair. Use paper or a piece of sheet vinyl (with backer side up) to level any dips in the subfloor.

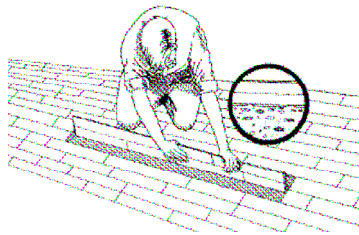

19. Place glue on top of the exposed tongues and slip-tongue in the repair cavity. Place small bead of glue on top of exposed tongues and spline in repair cavity.
Note: Do not place glue in the side groove in the repair cavity. A high quality yellow woodworking glue is recommended for board replacement.

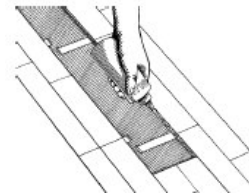

20. Insert the modified repair board tongue side first and at an angle, then tap into place using a rubber hammer.
Note: Do not use a rubber mallet. The rubber hammer should have a head no larger in diameter than 1-1/2".

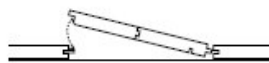
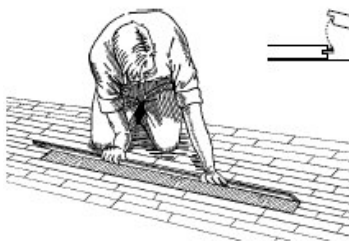

21. Press the board into repair cavity and remove any glue residue from the surface prior to drying.

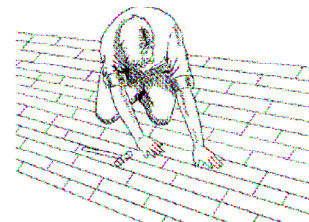

22. Using wood floor cleaner remove any glue from surface of the floor.

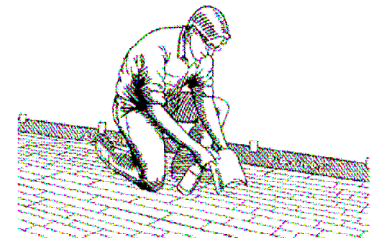

23. Place three five-gallon buckets of adhesive on the replacement board with weight distributed evenly across the repair board and adjoining boards. If five-gallon buckets of adhesive are not available, use three 25-30 lb. weights or weighted objects in their place. Allow the glue to dry. Protect floor from bucket bottoms/weights if needed. **Note:** When using a bucket, always use in conjunction with a tight-fitting lid to ensure its contents will not accidentally spill onto the floor.

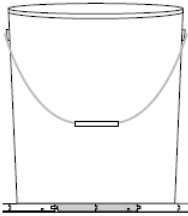

Gap Filling

WoodFlex flooring is a solid hardwood floor and expansion and contraction of the floor is normal. In many geographical areas with high humidity levels, WoodFlex flooring is installed with larger clips to allow for expansion to take place between the boards. Flexible joint filler is made for filling end gaps and irregular gaps only. Always allow a new floor 3-5 weeks to acclimate and expand (during low humidity months allow longer period).

Preparation for All Applications:

Areas for application should be thoroughly clean and dry. Remove any loose caulk, solvents, glue, paste, oils and debris.

Sealing/Filling

1. Apply only when surface is above 45°F.
2. Cut tip of flexible joint filler to desired bead size.
3. Completely fill joint with filler, apply evenly.
4. Smooth lightly with finger.
5. Wipe excess with cloth dampened with wood floor cleaner.
6. Repeat if necessary.

Filling Seams

1. Apply 2" blue painter's tape to both sides of seam area, exposing only the seam.
2. Use a clean putty knife to apply filler into seam and smooth.
3. Remove blue painter's tape after application.
4. Allow 24 hours curing before beginning maintenance program.